

VIII. TUBE RESEARCH AND DEVELOPMENT

A. MAGNETRON DEVELOPMENT

Dr. S. T. Martin
A. G. Barrett

1. Testing and Design of High Power 10.7-Cm Magnetrons

An important factor in making good metal-ceramic seals of the type described in the Quarterly Progress Report, January 15, 1952, has been found to be the amount of clearance between the ceramic disc and the kovar cup. In previous brazing trials this clearance was made as small as possible. Better wetting and bonding were observed when more space was provided for the solder to flow into the sealing area. Figure VIII-1 shows the details of the successful seal. The centering step also prevents solder from creeping out on the guard ring, thereby improving both high voltage and microwave performance.

The validity of this solution to the window problem is demonstrated by the fact that

tight windows have been made and assembled to three magnetrons. One assembly was made by the gold-wire seal method, and the other two windows were brazed on directly with BT solder. In addition, two test windows were made. One of these survived two brazing cycles to 800°C before developing a leak. The other window was pressure-tested to destruction and ruptured at 190 psi gauge.

Two magnetrons have been baked out and sealed off. The first, MF-10B, was baked at 650°C for 48 hours after 45 hours at 500°C. The second tube, MF-12B, was allowed to come up to 750°C under the control of the processing system. It required 66 hours to reach 750°C. The tube was maintained at this temperature for 7 hours, and at 700°C for 5.5 hours.

In the course of cooling down to room temperature, both magnetrons developed leaks registering on the 10^{-6} mm-scale of the ionization gauge. After we had sealed the leaks with glyptal, the pressure fell to the limit of the ion gauge used on the processing

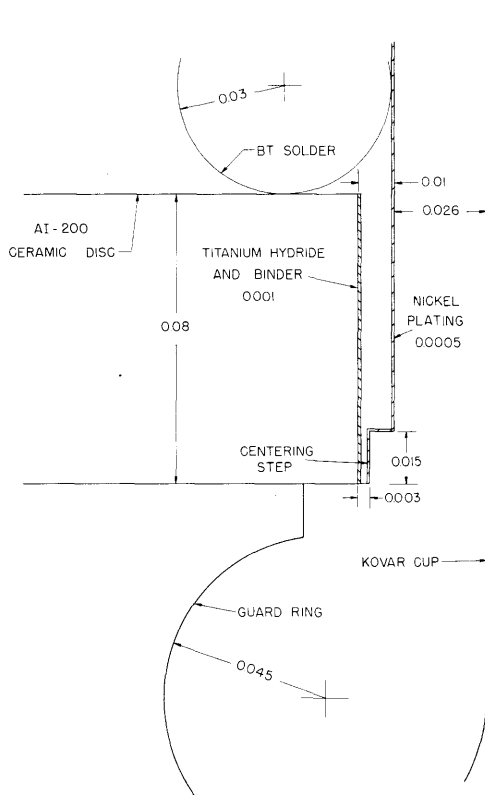

Fig. VIII-1
Cross section of window
metal-ceramic seal.

(VIII. TUBE RESEARCH AND DEVELOPMENT)

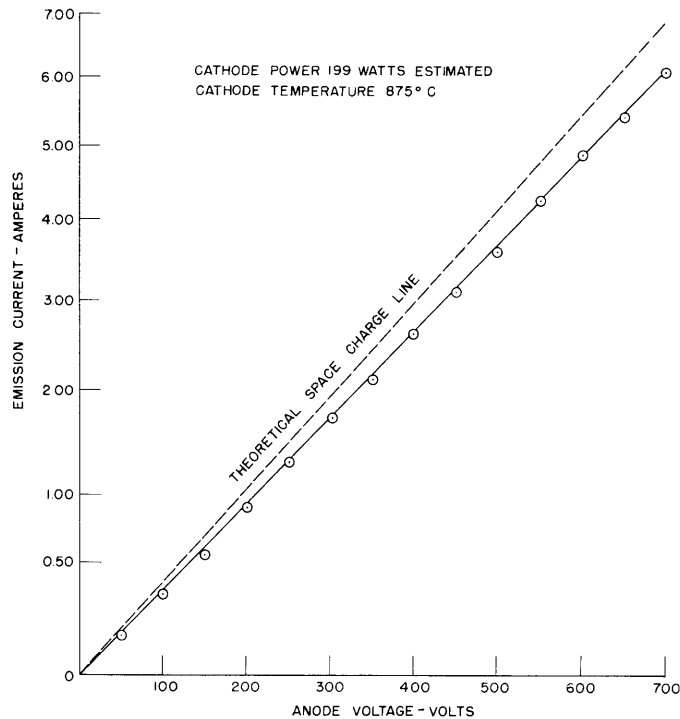

Fig. VIII-2

Initial cathode emission MF-10B magnetron.

system (10^{-8} mm Hg). Accordingly, both tubes were sealed off with the expectation that this circumstance would not obscure the principal experimental objective of the project.

The long bakeout time for these magnetrons was determined primarily by the breakdown of the cathode which occurred spontaneously at about 600°C . This time could be reduced, if a pressure limit higher than 2.5×10^{-4} mm Hg were allowed. Since the cathode breakdown was accomplished during bakeout, activation of the cathode in the normally understood sense was not required. As an example, Fig. VIII-2 shows the current vs voltage plot obtained in the first dc emission test of magnetron MF-10B.

Magnetron MF-10B has been operated for a total of 23.9 hours to date without showing any inherent limitations. Peak power of 3 Mw and average power of 1000 watts have been obtained. Test equipment problems have prevented operation at higher power.

Magnetron MF-12B will be operated on the test bench upon completion of tests with MF-10B. Magnetron MF-9B is nearly ready for final assembly and bakeout. Magnetron MF-11B, now in the window assembly stage, will complete the series of oxide-cathode magnetrons.

B. MICROWAVE TUBES

L. D. Smullin
 Prof. L. J. Chu
 A. D. Berk

A. W. Boekelheide
 H. A. Haus
 J. M. Houston
 R. C. Knechtli

C. E. Muehe, Jr.
 H. E. Rowe
 L. Stark

1. Noise and Space-Charge Waves

a. Effect of drifting on noise in beams with velocity spread

Zero space-charge interaction. An electron beam with a random velocity distribution and zero shot-noise at the input to a drift region exhibits an increase in noise current after having drifted for a certain length of time (1, 2). It is shown here that the electrons of a beam with any continuous velocity distribution tend asymptotically to a Poisson distribution.

We consider a beam with reduced shot noise whose electrons have arrival times at the input plane which are integral multiples of a time interval τ . We assume that the velocity of an entering electron is independent of the velocity of electrons ahead of it and behind it and obeys a probability distribution $p(v) dv$. The probability that an electron starts at the input plane at the time $t_i = n\tau$ and arrives at the output plane a distance L away in the time interval $t_o, t_o + dt_o$ is

$$P(t_i, t_o) dt_o = p\left(\frac{L}{t_o - n\tau}\right) \frac{L}{(t_o - n\tau)^2} dt_o.$$

This electron belongs to the velocity group $v, v + dv$ where

$$v = \frac{L}{t_o - n\tau}.$$

The probability of any electron arriving in $t_o, t_o + dt_o$ is

$$P(t_o) dt_o = \sum_n p\left(\frac{L}{t_o - n\tau}\right) \frac{L}{(t_o - n\tau)^2} dt_o.$$

For $t_o \gg n\tau$, we set

$$v_n = \frac{L}{t_o - n\tau} \quad \Delta v_n = \frac{L}{(t_o - n\tau)^2}.$$

The result is

$$P(t_o) dt_o = \frac{dt_o}{\tau} \sum p(v_n) \Delta v_n.$$

(VIII. TUBE RESEARCH AND DEVELOPMENT)

If the velocity distribution is continuous, then

$$\lim_{t_0 \rightarrow \infty} \sum_n p(v_n) \Delta v_n = \int p(v) dv = 1$$

and we obtain

$$P(t_0) dt_0 = \frac{dt_0}{\tau}. \quad (1)$$

The probability of the arrival of an electron in the time interval $t_0, t_0 + dt_0$ becomes independent of t_0 . This is the basic condition underlying a Poisson distribution in arrival times.

In presence of space-charge interaction. Space-charge forces attempt to preserve an order originally present in the beam. It is to be expected that complete disorganization will not occur.

Equation 2 of the Quarterly Progress Report, January 15, 1952 (3) has been extended to apply to the treatment of noise in a multiveLOCITY stream

$$\int J_1(v, x, \omega) dv = \frac{1}{2\pi j} \int_{c-j\infty}^{c+j\infty} \frac{\int \frac{J_1(v, 0, \omega)}{p + j\frac{\omega}{v}} dv}{1 + \frac{e}{m\epsilon} \int \frac{\rho_0(v)}{(\omega - jvp)^2} dv} e^{px} dp. \quad (2)$$

The integral has to be carried out over all velocities. Interchanging the order of integration gives

$$I(x, \omega) = \int J_1(v, x, \omega) dv = \int J_1(v, 0, \omega) F(v, x, \omega) dv \quad (3)$$

where $I(x, \omega)$ is the amplitude of the total current at the point x , and

$$F(v, x, \omega) = \frac{1}{2\pi j} \int_{c-j\infty}^{c+j\infty} \frac{e^{px} dp}{\left(p + j\frac{\omega}{v}\right) \left(1 + \frac{e}{m\epsilon} \int \frac{\rho_0(v)}{(\omega - jvp)^2} dv\right)}.$$

In the case of noise, only statistical averages of $J_1(v, 0, \omega)$ are known. Similarly, we are interested only in the quantity $\overline{|I(x, \omega)|^2}$, the bar denoting an ensemble average. We find from Eq. 3

$$\overline{|I(x, \omega)|^2} = \iint J_1(v, 0, \omega) J_1^*(s, 0, \omega) F(v, x, \omega) F^*(s, x, \omega) dv ds. \quad (4)$$

(VIII. TUBE RESEARCH AND DEVELOPMENT)

$F(v, x, \omega)$ has the meaning of a transfer function and is the same for all members of the ensemble. We define

$$\overline{\phi(v, s, \omega)} = \overline{J_1(v, \omega) J_1^*(s, \omega)} \quad (5)$$

as the cross-power spectrum of the currents in the velocity groups v , $v + dv$ and s , $s + ds$. In this new notation

$$\overline{|I(x, \omega)|^2} = \iint \overline{\phi(v, s, \omega)} F(v, x, \omega) F^*(s, x, \omega) dv ds. \quad (6)$$

Assuming that the dispersion equation

$$1 + \frac{e}{m\epsilon} \int \frac{\rho_0(v) dv}{(\omega - jv)^2} = 0$$

has n roots p_k , we find for $\overline{|I(x, \omega)|^2}$

$$\begin{aligned} \overline{|I(x, \omega)|^2} &= \sum_{i, k} e^{(p_i + p_k^*)x} \iint \overline{\phi(v, s, \omega)} A_i(v, \omega) A_k^*(s, \omega) dv ds \\ &+ \sum_i e^{p_i x} \iint \phi(v, s, \omega) A_i(v, \omega) B^*(s, \omega) e^{j\frac{\omega}{s}x} dv ds \\ &+ \sum_k e^{p_k^* x} \iint \phi(v, s, \omega) A_k^*(s, \omega) B(v, \omega) e^{-j\frac{\omega}{v}x} dv ds \\ &+ \iint \phi(v, s, \omega) B(v) B^*(s) e^{j\left(\frac{\omega}{s} - \frac{\omega}{v}\right)x} dv ds. \end{aligned} \quad (7)$$

The last term in Eq. 7 is the only one remaining in the limit of zero-space charge. Authors treating this case worked essentially with this term.*

In the limit of $x \rightarrow \infty$, only the first and the last term in Eq. 7 can be different from zero. The first term represents the organized plasma behavior, the last term is the result of waves analogous to gas modes (4).

The cross-power spectrum of a beam whose drift region is preceded by a short space-charge limited gun can be expressed at frequencies $f \ll 1/\tau$

*The expressions derived in references 1 and 2 can be obtained from this term by means of the boundary conditions given in Eq. 8.

(VIII. TUBE RESEARCH AND DEVELOPMENT)

$$\phi(v, s, \omega) = 2eI_0 \Delta f \left[\frac{v}{\bar{v}} p(v) \delta(v-s) - (1 - \Gamma^2) \frac{v}{\bar{v}} p(v) \frac{s}{\bar{v}} p(s) \right] \quad (8)$$

where

$$\bar{v} = \int v p(v) dv$$

and δ is the Dirac delta function. By specifying $p(v)$ as a square pulse distribution (see Fig. VIII-3), we find in the limit $x \rightarrow \infty$ that the first term in Eq. 7 gives a standing-wave pattern with a standing wave ratio of the mean-square noise current

$$SWR = 12 \left(\frac{\omega_p}{\omega} \frac{w}{a} \Gamma \right)^2$$

where

$$\omega_p^2 = \frac{e}{m\epsilon} \frac{I_0}{v}$$

The contribution of the gas modes to the total mean-square current is

$$\frac{1}{15} eI_0 \Delta f \left(\frac{\omega}{\omega_p} \frac{a}{w} \right)^4$$

whereas the maximum of the standing wave of the mean-square noise current is of the order of

$$2eI_0 \Gamma^2 \Delta f$$

when $\Gamma \neq 0$, or

$$2eI_0 \frac{a^2 \omega^2}{12w^2 \omega_p^2} \Delta f$$

when $\Gamma = 0$.

The gas modes, which cause a smoothed beam with zero space charge interaction to approach full-shot noise, give a negligible contribution to the noise current when space-charge forces are strong $\omega_p/\omega \gg a/w$.

We can conclude that in this special case the space-charge forces prevent complete disorganization in the beam. They do not allow full-shot noise to arise if the beam was originally smoothed.

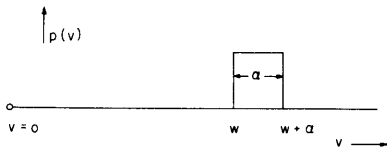

Fig. VIII-3
Distribution function.

H. A. Haus

(VIII. TUBE RESEARCH AND DEVELOPMENT)

References

1. D. K. C. MacDonald: *Phil. Mag.* 40, 561, 1949 and 41, 863, 1950
2. F. N. H. Robinson: *Services Electric Research Laboratory Quarterly Report*, 18, 43, April 1950
3. *Quarterly Progress Report, Research Laboratory of Electronics, M.I.T.* Jan. 15, 1952, p. 36
4. D. Bohm, E. P. Gross: *Phys. Rev.* 75, 1851, 1949

b. Experimental study of noise in electron beams

Because of the exponential increase in noise described in the Quarterly Progress Report, January 15, 1952, and the supposition that this might be related to some unknown amplifying mechanism, the apparatus was operated as a two-cavity klystron to see what the behavior of impressed signals would be. The same gun, previously described in the Quarterly Progress Report, January 15, 1952, was used. The results are presented in Figs. VIII-4 and VIII-5. The output of the second cavity is plotted as a function of distance for different levels of excitation of the first cavity. The lowest curve in each case corresponds to the noise excitation of the second cavity. This, however, is generally not the same as that measured with the first cavity in the usual standing-wave curves, because the first cavity affects the noise behavior of the beam. Figure VIII-4 is for the case of approximately Brillouin field, Fig. VIII-5 for a much larger magnetic field.

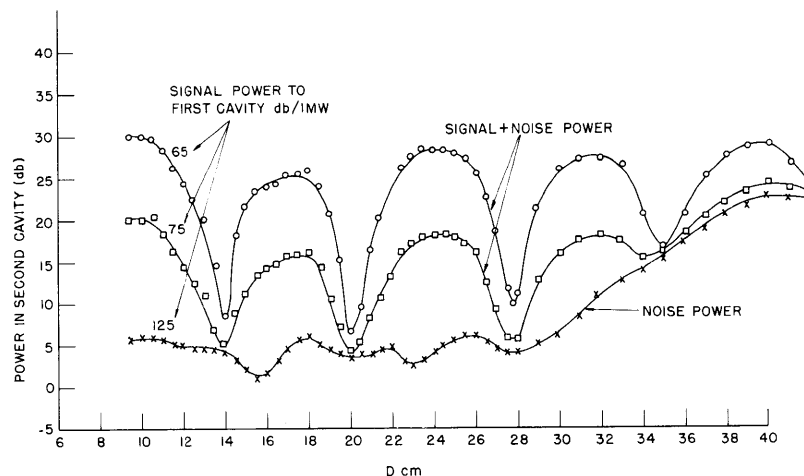

Fig. VIII-4

Output of second cavity vs distance for various applied signal levels at first cavity. $D_1 = 6$ cm; $V_k = 1200$ volts; $I_t = 5.7$ ma; $V_f = 10.5$ volts; $I_h \approx 60 \mu\text{a}$; $P = 7 \times 10^{-7}$ mm; $B \approx 190$ gauss.

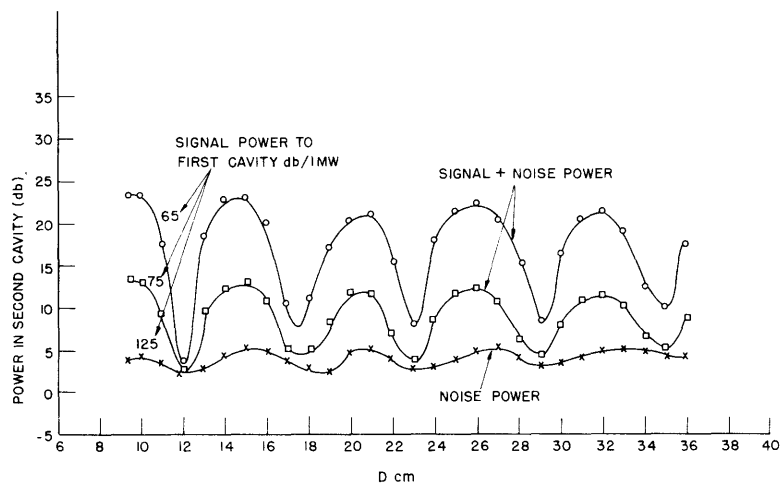

Fig. VIII-5

Output of second cavity vs distance for various applied signal levels at first cavity. $D_1 = 6$ cm; $V_k = 1200$ volts; $I_t = 5.7$ ma; $V_f = 10.5$ volts; $I_h \approx 60 \mu\text{a}$; $P = 7 \times 10^{-7}$ mm; $B = 630$ gauss.

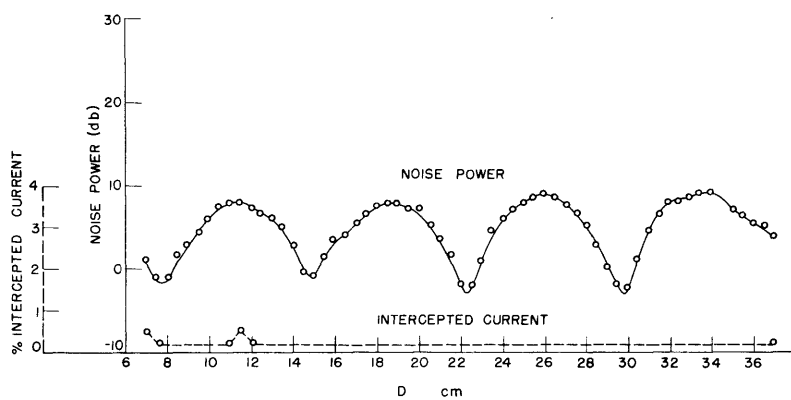

Fig. VIII-6a

Noise and interception current vs distance. $V_k = 1090$ volts; $B = 280$ gauss; $P = 2.5 \times 10^{-7}$ mm; $V_f = 7.9$ volts; $I_t = 4.2$ ma.

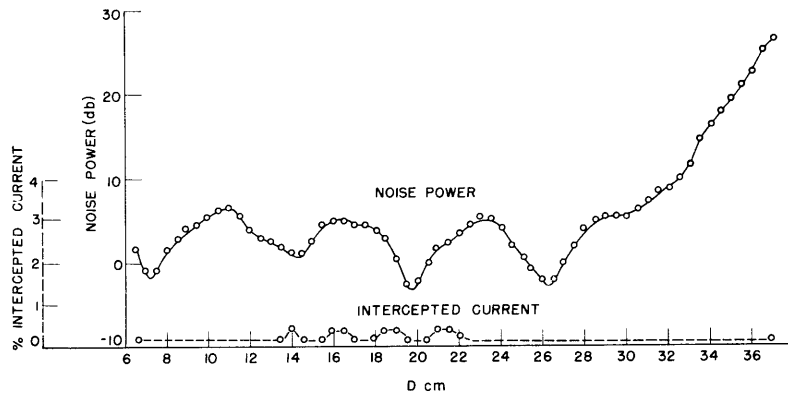

Fig. VIII-6b

Noise and interception current vs distance. $V_k = 1090$ volts;
 $B = 280$ gauss; $P = 3 \times 10^{-7}$ mm; $V_f = 9$ volts; $I_t = 5.6$ ma.

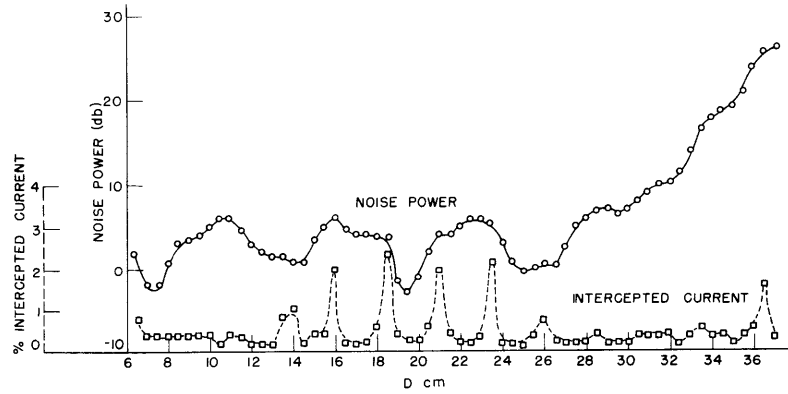

Fig. VIII-6c

Noise and interception current vs distance. $V_k = 1090$ volts;
 $B = 280$ gauss; $P = 5 \times 10^{-7}$ mm; $V_f = 10$ volts; $I_t = 5.7$ ma.

(VIII. TUBE RESEARCH AND DEVELOPMENT)

Two general observations may be made. The first is that there is no amplification of the applied signal. The second is that increasing the magnetic field seems to have relatively little effect on the applied signal, in comparison with the rather large effect it has in raising the minima of the noise standing-wave patterns.

Another important effect has been noted. If the filament voltage is reduced slightly at low magnetic field (i. e. at conditions corresponding to an exponential increase of noise, so that the beam current is slightly reduced), the intercepted current will be greatly reduced, the exponential increase in noise will disappear, and the standing-wave curve will become more regular and will more nearly resemble a standing-wave curve. The behavior then corresponds more closely with that observed in earlier studies with a lower perveance gun. This behavior is illustrated in Fig. VIII-6. Reducing V_k , the accelerating voltage, does not produce this effect.

It is not known at present whether this behavior is caused by varying the temperature of the cathode, by changing the perveance of the gun, or by altering the flow conditions inside the gun in some manner. However, it has been noted before that small changes in the filament voltage may alter the intercepted current very greatly.

An informal summary of the work done on this problem is being written.

H. E. Rowe

The demountable system described in previous Quarterly Progress Reports is now operating satisfactorily. The indicated operating pressure is approximately 5×10^{-7} mm Hg. Two electron guns with the same design (perveance 0.1×10^{-6} amp/volt^{3/2}, beam diameter approximately 0.050 inch) have been operated in the system since the Quarterly Progress Report, January 15, 1952. Measurements of beam diameter have been made using a sliding carbon film target and a movable shutter. The measurements agreed to within about 15 percent. Because of the thickness of the cross hairs and the brightness of the spot, it was difficult to set the cross hairs on the edge of the beam with the low-power telescope used. Further, the transverse motion of the telescope could only be read to a tenth of a millimeter, so the readings using the carbon film target were certainly not better than 10 percent.

The noise current in the beam has been measured using a cavity, and the results agree with those of Mr. H. E. Rowe as reported above.

The measurements of beam diameter point to the fact that, even though the indicated pressure is about 5×10^{-7} mm Hg, the beam in the drift tube is completely neutralized. The measurements and theory are outlined below. In order to confirm these conclusions and to see how differently an unneutralized beam behaves, a modulator has been assembled to drive the gun with 1- μ sec pulses at a repetition rate of several thousand pulses per second. The apparatus is now complete, but as yet no data have been taken.

(VIII. TUBE RESEARCH AND DEVELOPMENT)

When an electron beam formed in a field-free region is not properly started in the magnetic field used to confine it, perturbations in the beam diameter will exist. The wavelength of these perturbations (1) is

$$\lambda = \sqrt{2} \frac{2\pi\dot{z}}{\eta B}.$$

This equation holds very well even for large perturbations as shown by the work of Moster and Molnar (2) and neglects any effects due to positive ions. The equation for radial motion in an electron beam originating in a field-free region is

$$\ddot{r} = \eta \frac{\partial V}{\partial r} - \frac{\eta^2 B^2 r}{4}.$$

If the beam is fully neutralized by positive ions

$$\frac{\partial V}{\partial r} = 0$$

and

$$\ddot{r} + \left(\frac{\eta B}{2}\right)^2 r = 0.$$

The solution of which is

$$r = A \text{Sin} \frac{\eta B}{2} t + B \text{Cos} \frac{\eta B}{2} t.$$

The constants A and B are determined from the values of r and dr/dt at z = 0. It is easy to see that A and B are both real numbers which leads to the fact that all the electrons in the beam pass through the axis of the beam. This rules out the possibility of a uniform beam radius in the presence of full ion neutralization when the gun is in a field-free region. The above analysis assumes that the positive ions exactly fill up the potential depression inside the beam. An excess presumably would form a larger diameter positive-ion beam but the electron beam would be almost exactly neutralized.

The wavelength of the perturbations when the beam is fully neutralized is

$$\lambda_c = \frac{2\pi\dot{z}}{\eta B} = \frac{\lambda}{\sqrt{2}}.$$

At the pressures, currents, and voltages used in the apparatus employed by the author, the beam is believed to be fully neutralized over most of its length. Following is a table showing calculated values of λ_c and measured values of λ_c observed in the apparatus. The beam diameter was measured by putting a shutter with a small hole in front of the beam and observing the fraction of current passing through the hole as a function of distance along the beam. Then by assuming uniform current density across the beam, the beam diameter was calculated.

(VIII. TUBE RESEARCH AND DEVELOPMENT)

V (volts)	B (gauss)	λ_c Calculated (meters)	λ_c Measured (meter)	$\frac{\lambda_c \text{ Measured}}{\lambda_c \text{ Calculated}}$
1000	108	0.0617	0.0710	1.15
1500	198	0.0412	0.0466	1.13
1000	212	0.0315	0.0346	1.10
1000	353	0.0189	0.0194	1.03

If Brillouin flow existed, the ratio in the last column would be 1.414.

References

1. J. R. Pierce: Theory and Design of Electron Beams, Van Nostrand Co., New York, 1949
2. C. R. Moster, J. P. Molnar: Some Calculations of the Magnetic Field Requirements for Obtaining Brillouin Flow in Cylindrical Electron Beams, Memo for File, Bell Telephone Laboratory Series, Jan. 16, 1951

C. E. Muehe, Jr.

2. Traveling-Wave Amplifiers

a. 10-cm pulsed traveling-wave amplifier

The first model of the tube described in the Quarterly Progress Report, January 15, 1952, has been built. The tube required three weeks to pump and process, probably due to the large areas of cold-rolled steel in the gun, some of which were oxidized when the envelope was sealed.

Beam tests were then run. The gun perveance measured about 1.4×10^{-6} amp/volt^{3/2}, both under dc tests to 1000 volts and pulsed tests to 18 kv. Only about 70 percent of the cathode current could be collected at the collector with a magnetic field about twice the Brillouin field. A check showed that the magnetic correcting circuits used to continue the axial magnetic field across the waveguide input and output, were saturating. New magnetic circuits have been designed and are being built. A gun tester is being assembled to check the beam shape as it emerges from the gun, without a magnetic field. It is felt that, after the above tests and changes, an electron flow closer to Brillouin conditions will be realized.

Next, the tube was run as an oscillator with no extra loss on the helix. It oscillated at about $\lambda_o = 8$ cm with a peak power output of about 500 watts. The peak input voltage and current were 18 kv and 2 amp. At this point one of the tube seals was accidentally

(VIII. TUBE RESEARCH AND DEVELOPMENT)

cracked, so no further tests were made. A second tube will be constructed with numerous mechanical design changes to avoid troubles present in tube No. 1.

J. M. Houston

b. Interleaved-fin slow-wave structure

A number of experiments have been performed to check the theory based on the simple model of the interleaved-fin structure outlined in the Quarterly Progress Report, January 15, 1952.

Measurements made on the 180° bend (in rectangular waveguide) indicate that the calculation of discontinuity susceptance is quite accurate. Measured points for the curve $d/L = 0.75$ agree to within 1 percent of the calculated curve. In this measurement the ratio of septum thickness to guidewidth L was 0.023.

Measurements of the axial electric-field distribution with coordinate x have led to a very simple picture of the mode behavior. The measurements indicate that in the allowed regions of the propagation constant, the field distribution is very nearly that which would result if a magnetic wall were placed along each open side. This gives electric field distributions within the structure of the form

$$E_z = \cos \frac{m\pi x}{w}; \quad m = 0, 1, 2 \dots$$

where the origin for x is at one of the magnetic walls. The cut-off wavelength for the m th mode is given by

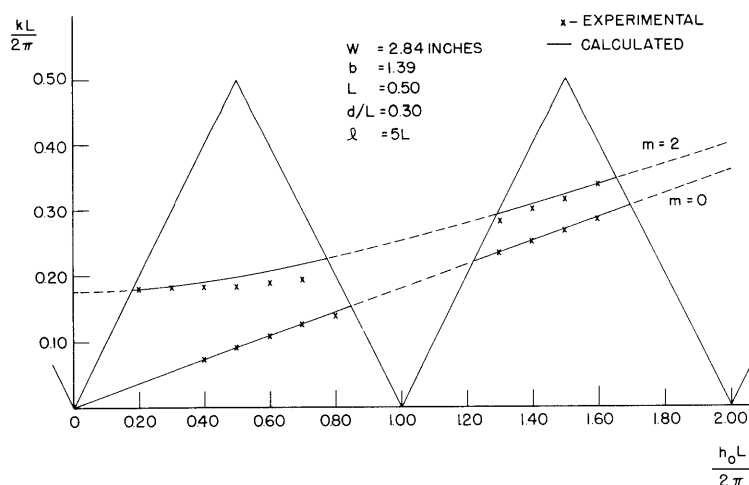
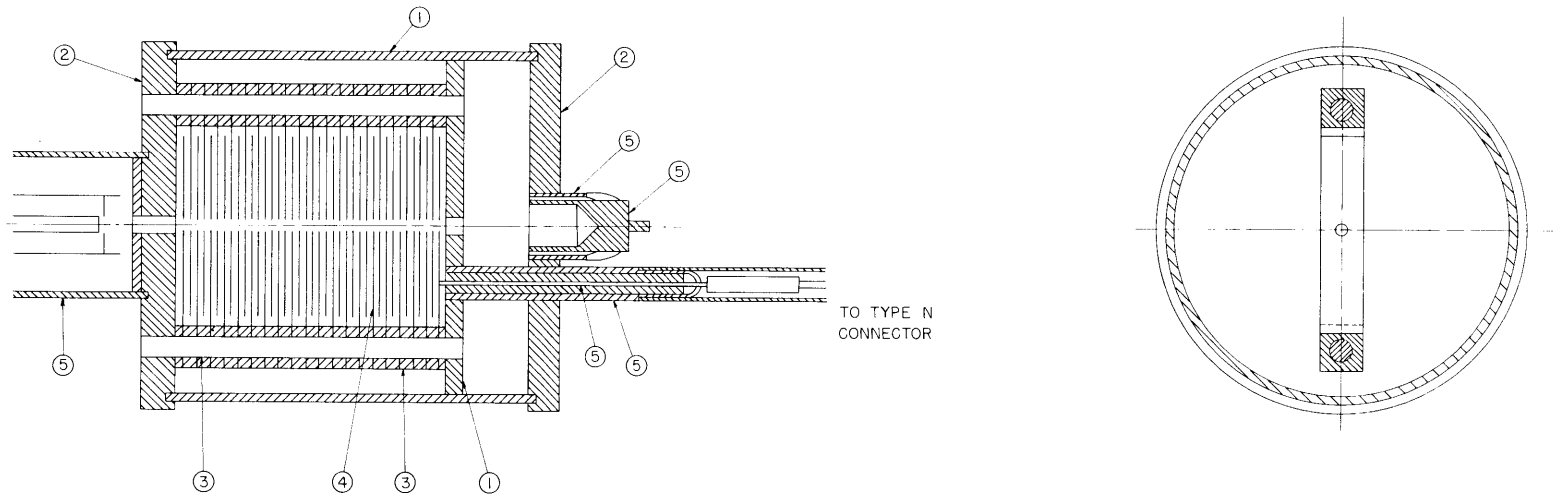

Fig. VIII-7

Plot of frequency as a function of propagation constant for the $m = 0, m = 2$ modes.



- ① OFHC COPPER
- ② ARMCO IRON
- ③ 303 STAINLESS
- ④ MOLY
- ⑤ KOVAR

Fig. VIII-8
Ten-centimeter interleaved-fin traveling-wave oscillator.

(VIII. TUBE RESEARCH AND DEVELOPMENT)

$$\lambda_{\text{cm}} = \frac{2w}{m}.$$

The result of using this model as a basis for calculation of the frequency as a function of propagation constant is plotted in Fig. VIII-7. Measured points are also plotted, showing that the above picture is quite accurate.

Work has been started on a practical evaluation of the interleaved-fin structure as a traveling-wave oscillator circuit. A tube with a 2-kv beam carrying 10 ma has been designed to operate at 10 cm. A scale drawing of the tube is shown in Fig. VIII-8.

Correction for page 45, Quarterly Progress Report, January 15, 1952:

In the space harmonic representation for E_z , multiply this expression by $1/\sin(h_o L/4)$. The expression for the impedance should be multiplied by the square of this factor and the plot of impedance (see Fig. VIII-4) should be used accordingly.

L. Stark

3. 1-Mev Pulsed Electron Source

The high-voltage cathode ray tube again was reassembled with a new glass envelope, but after it had been baked and pumped for several days, the envelope mysteriously broke. No reason for the failure was apparent, as the remaining pieces of glass appeared to be quite well annealed and free of strains even after the implosion. Irregularities in the hand-blown, 8.5-inch diameter envelope may have been the cause, however. The 7052 glass which must be used is very difficult to work, especially in such a large size. However, the Corning Glass Company now has developed a new kovar-sealing glass which may help solve the envelope construction problem. The new glass is not yet on the market, but it probably will be within a few months.

Since this was the fifth failure of the envelope of this tube, and since the most serviceable electrodes were ruined in the implosion, it seemed advisable to reanalyze the entire problem of the high-voltage tube. This reanalysis now is being carried out. An effort is being made to reduce the physical size of the tube, in order to alleviate the construction problem. However, this reduction involves two additional problems: first, the minimum possible interelectrode spacing and maximum possible voltage gradient which can be used; and, second, the design of a smaller electrode system to give the desired current and current density at the operating voltage (1 Mv).

Very little is known at the present time about voltage breakdown in vacuum under pulsed conditions involving a voltage of 1 Mv and a gradient of several hundred kilovolts per inch. Therefore, the minimum possible interelectrode spacing which can be used remains a mere estimate. The results of using beams of varying angles of convergence and of varying current densities are being studied, in an effort to achieve a smaller design which still creates the proper electric field conditions.

(VIII. TUBE RESEARCH AND DEVELOPMENT)

The problem of bringing the beam through a metallic window into the atmosphere also is being restudied. It is hoped that a smaller, more efficient, and more easily constructed window can be used in place of the present, 0.001-inch thick, 2-inch diameter stainless steel window. Also, it is hoped that the final design will eliminate the necessity of defocusing the beam with a magnetic lens in order to bring it through the window.

A. W. Boekelheide