

XIX. SHOP NOTES

A. IMPROVEMENTS ON A PUNCHED CARD SELECTOR FRAME

Hand-sorted punched card systems are commonly used for filing and cross-indexing literature reference material. However, the use of such a system is worthwhile only if the speed and ease of finding the desired material are greater than the similar time spent in preparing duplicate cards under an alphabetical subject-and-author system of filing. For some time the microwave gas discharge group has been using the McBee Company "Keysort" cards for its literature file, and has made a number of improvements on the standard available equipment for card sorting which increases both the speed and ease of use.

If a file does not include more than a few hundred cards, sorting with a hand needle is perfectly satisfactory. For larger numbers of cards, a standard frame selector is available which has the advantages of sorting more cards at once than can be done conveniently with a hand needle and of requiring no physical effort in sorting. The disadvantage of the frame selector is that it is difficult to agitate the cards sufficiently to insure complete separation of the wanted cards. To overcome this trouble, we mounted the selector on shock mounts and vibrated it mechanically. The vibration was caused by an unbalanced flywheel powered by a 1/20 horsepower electric motor firmly attached somewhat off-center to the rear base of the selector.

Our literature file is arranged for direct coding of subject material and numerical coding of authorship. Since the file is almost always searched by subject, single-pin selection is common. Using a mechanical selector, single-pin selection in the positions near the center of the card works very well, but within about ten holes of either end of the card the rotation of the card about the selector pin tends to jam the cards against the top of the frame and to reduce the ease with which the punched cards will fall out. To improve this feature, we have built a card support that prevents the rotation of the cards while they are being vibrated. This support is illustrated in Fig. XIX-1 in the position in which the cards are put onto the selector frame. The support may be put onto the frame on either end of the cards, dictated by the position of the selector pin about which the card might rotate. The support is of Dural and is attached by compressing the wing ears of the spring clips and sliding the support along the guide rods, mounted on the top of the selector frame, until the support meets a stop block. When the wing ears are released, spring clips engage slots in the guide rods which locate the exact position of the support.

A view of the modified selector frame is shown in the photograph in the selecting position (Fig. XIX-2). To eliminate the noise which the frame makes when mechanically vibrated, several steps had to be taken. All metal washers throughout the frame were replaced by rubber ones. The sorting tray was held down by the springs, shown in Fig. XIX-2, when the direct coding along the long edge of the card was being used. When

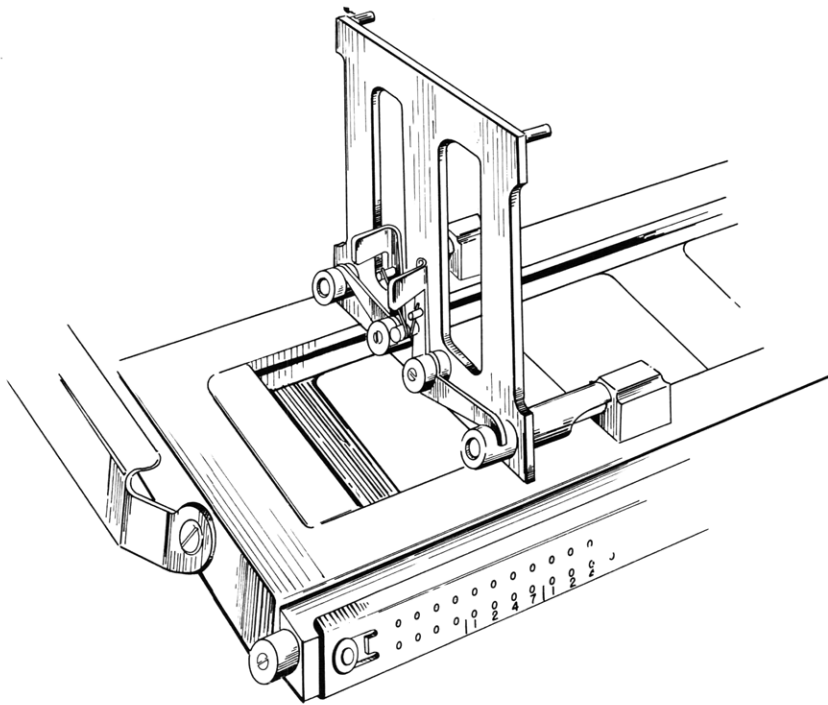

Fig. XIX-1
Detail of the card support.

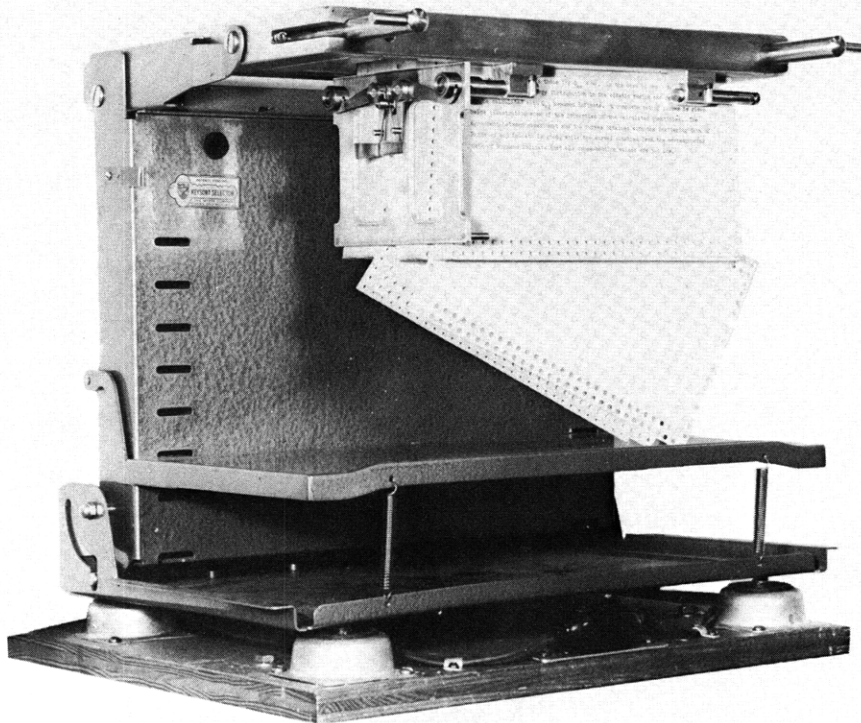

Fig. XIX-2
Improvements on a punched card selector frame.

(XIX. SHOP NOTES)

the coding at the end of the cards was used, the springs were disconnected, and the sorting tray was folded up against the back of the frame, held by the clips, which are also shown. The switch on the motor vibrator can be seen in Fig. XIX-2, though the motor itself is on the back of the frame.

S. C. Brown, J. E. Coyle

B. VACUUM-TIGHT GLAND FOR PUSH-ROD AND ROTATING SHAFT APPLICATIONS

The basis of the gland is a Lunkenheimer No. 1324 compression tee, 3/8 inch tubing size. The body A (Fig. XIX-3) is reamed through to take the rod B, a piece of 3/8 inch stainless steel rod, which has been polished. The crosspin E is a piece of 1/8 inch round stainless steel, force-fit, that serves to tighten or loosen the nut D which is inside

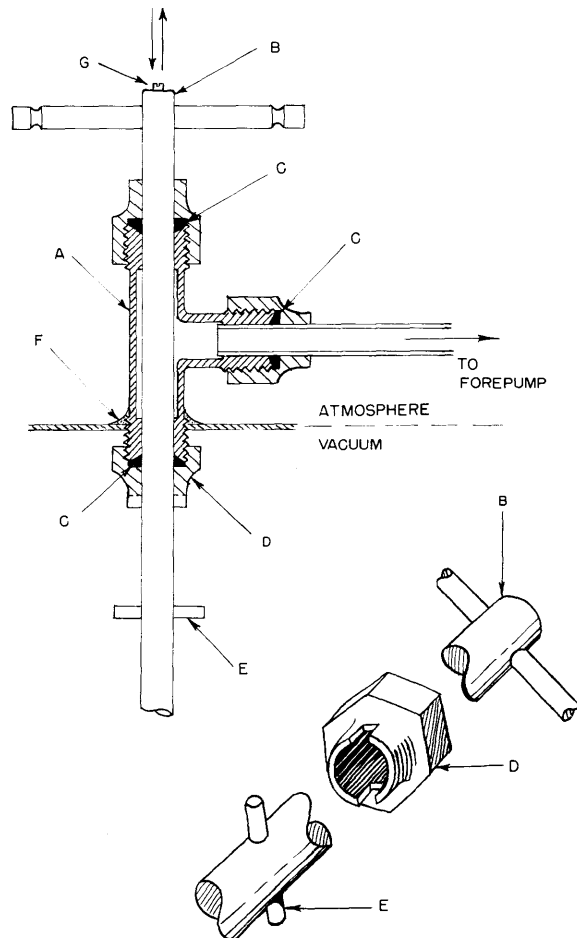

Fig. XIX-3
Vacuum-tight gland.

the evacuated chamber. The three packings C are made from 5/8 inch Teflon rod, turned, as shown, to the shape to fit the seats in the tee body originally intended for the copper compression sleeves that are not used. The Teflon pieces need not be made with high precision because when the nuts are tightened the Teflon will cold-flow into place. Note that the nut inside the vacuum D has been modified: a slot has been milled in it to take the crosspin B, and also some of the hexagon body has been turned off to allow space for mounting the tee in the vacuum wall, and to allow space for tightening. The tee is hard-soldered into the vessel wall at F. The cross handle at B is a loose fit to allow for assembling; it may be fixed in place by means of a setscrew G.

A mixture of Octoil with some molybdenum disulphide sparingly applied to the friction surfaces made operation of the gland adequately smooth both for turning and sliding motions.

F. J. O'Brien, F. Rosebury

C. VACUUM COLD TRAP

The body of the trap is a cylinder of seamless stainless steel tubing 4 inches in diameter; the 2-inch-diameter inlet and outlet tubes are Kovar, which allows a glass-to-metal seal. The partition, shown in Fig. XIX-4, is a piece of stainless steel sheet, cut to fit snugly inside the diameter of the cylinder and extending to within approximately

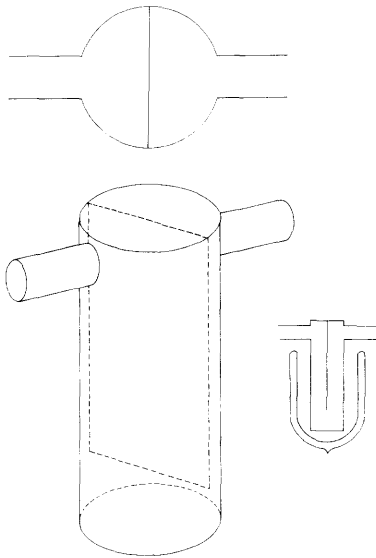

Fig. XIX-4
Vacuum cold trap.

1.5 inches of the bottom. This sheet is first tack-welded to the top disc. The edges and top are tinned with soft solder before assembling into the cylinder the inside walls of which are also tinned along the areas of contact. The inlet and outlet tubes and the top and bottom discs are welded or brazed in place, and upon applying heat along the outside of the cylinder at the places where the partition is in contact a seal is effected by the soft solder.

A feature of this trap is the cold partition which is essentially at the same temperature as the cylinder walls because of the metallic contact, thus providing a large area of cooling surface in a trap of relatively small size. The trap was designed for use with a one-gallon dewar flask.

The inlet and outlet tubes may, of course, be attached at almost any position and not limited to the 180° position shown in Fig. XIX-4.

F. Rosebury

(XIX. SHOP NOTES)

D. ELECTRIC VACUUM SEAL

The seal was designed to eliminate gasketing material. The detailed unit (Fig. XIX-5) is approximately 25 inches in diameter. The reservoir was made from rectangular steel tubing with one narrow side removed. The heating element is a 3500-watt, 230-volt General Electric 4A-422 immersion unit, 0.333 inch in diameter.

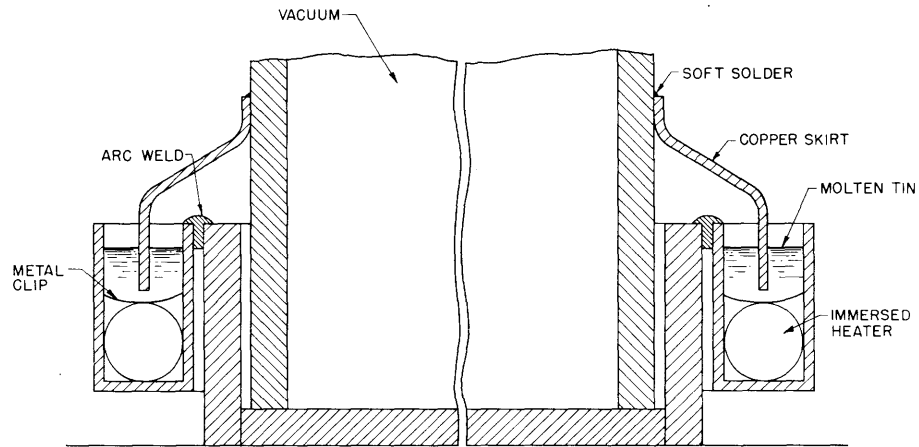

Fig. XIX-5

Diagram shows skirt immersed in molten tin bath.

To make a seal, the reservoir on the lower half is heated until the tin or solder is molten. The upper half with the skirt is lowered into the reservoir and allowed to cool. Any section that does not wet satisfactorily can be readily touched up. After a few seals are made and opened, the skirt becomes completely tinned and the seal goes together easily.

J. B. Keefe