

XIII. NETWORK SYNTHESIS

Prof. E. A. Guillemin
Prof. P. M. Lewis II

Dr. M. V. Cerrillo

H. B. Lee
T. G. Stockham, Jr.

A. IMBEDDING GAIN IN RC NETWORKS BY MEANS OF LINEAR TRANSFORMATIONS

Methods of synthesizing passive RC networks for prescribed driving-point and transfer characteristics are fairly numerous (1). Also, contrary to intuitive belief, a passive RC network can be made to approximate any prescribed transfer characteristic defined along the $j\omega$ -axis with an arbitrary degree of accuracy, except for a possible scale factor. Thus if some form of gain can be imbedded in such networks – once they are obtained by conventional methods – they can enjoy a broader field of usefulness. Such a scheme that employs linear transformations of the network variables will now be discussed.

Let us assume that we have a network that is passive and meets all of our desires as far as its driving-point and transfer impedances are concerned, with the exception that some of these impedances differ from the desired values by a constant of proportionality. This may mean that the transfer impedance is too low, which results in too small a gain, or that the driving-point impedance is too low or too high, which loads down the source (whatever its character) excessively or reduces the effective gain when the device is being used to provide a dimensionless transfer ratio.

There are several ways of correcting these undesirable conditions. A simple way is to reinforce the gain with a vacuum tube or to use impedance leveling on the network, or both. The first technique will work if the tube does not load the network appreciably (i. e., if the stage isolates). If the use of transistors that do not isolate is demanded, then the solution is not so obvious. It is this situation with which the present treatment is concerned.

Most, if not all, of the RC synthesis techniques end with, or can be modified to end with, one of the two configurations shown in Fig. XIII-1. In this figure the boxes marked "RC" contain capacitors and, perhaps, some resistors. For the sake of discussion,

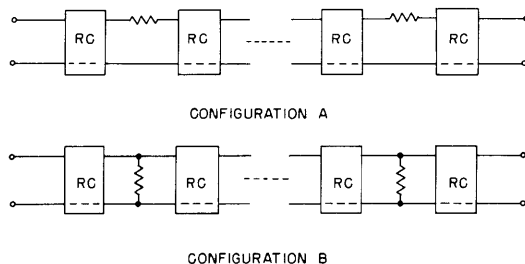

Fig. XIII-1. Typical RC passive configurations.

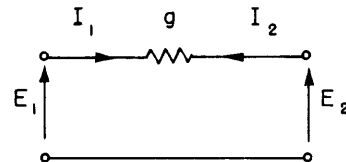

Fig. XIII-2. Simple coupling network.

(XIII. NETWORK SYNTHESIS)

let us assume that we are dealing with configuration A, and that we wish to improve this result by means of nonisolating transistors. If we take configuration B, a dual argument follows. Focus attention upon the simple coupling network shown in Fig. XIII-2. This network has the conductance matrix

$$G = \begin{bmatrix} g & -g \\ -g & g \end{bmatrix} \quad (1)$$

Equilibrium is expressed by the matrix equation

$$I] = [G] E] \quad (2)$$

where

$$I] = \begin{bmatrix} I_1 \\ I_2 \end{bmatrix} \quad \text{and} \quad E] = \begin{bmatrix} E_1 \\ E_2 \end{bmatrix} \quad (2a)$$

Now let us perform a particular linear transformation on $E]$, and another upon $I]$, as follows.

$$E'] = A \cdot E] = \begin{bmatrix} h E_1 \\ k E_2 \end{bmatrix} \quad (3)$$
$$I'] = B \cdot I] = \begin{bmatrix} i I_1 \\ j I_2 \end{bmatrix}$$

Then $[A]$ and $[B]$ are

$$[A] = \begin{bmatrix} h & 0 \\ 0 & k \end{bmatrix} \quad (4)$$
$$[B] = \begin{bmatrix} i & 0 \\ 0 & j \end{bmatrix}$$

Taking the inverse of Eqs. 3, we obtain

$$E] = [A]^{-1} E'] \quad (5)$$
$$I] = [B]^{-1} I']$$

If we substitute Eqs. 5 in Eq. 2, we obtain

$$[B]^{-1} I'] = [G] [A]^{-1} E'] \quad (6)$$

and premultiplication of both sides by $[B]$ finally yields

$$I'] = [B] [G] [A]^{-1} E'] \quad (7)$$

or

$$I'] = [G'] E'] \quad (7a)$$

where

$$[G'] = [B] [G] [A]^{-1} = \begin{bmatrix} ih^{-1}g & -ik^{-1}g \\ -jh^{-1}g & jk^{-1}g \end{bmatrix} \quad (8)$$

This new $[G']$ matrix is no longer passive or bilateral, as is $[G]$, and it can only be realized through the use of a vacuum tube, or a transistor, or the like. The reason behind the introduction of the transformations $[A]$ and $[B]$ is readily seen if we examine the quantities P and P' given by

$$P = \underline{E}] I] \quad (9)$$

and

$$P' = \underline{E}'] I'] \quad (10)$$

which, through Eqs. 2a and 3, become

$$P = E_1 I_1 + E_2 I_2 \quad (11)$$

$$P' = ih E_1 I_1 + jk E_2 I_2 \quad (12)$$

P represents a positive definite quadratic form because it is the power delivered to a passive network; P' might not be of such a character, however, and thus we see that the new coupling network might be able to improve the performance of the device. Indeed, a proper choice of the scale factors, h , i , j , and k will enable the coupling network to accomplish the desired effects that have been discussed. The ideas involved in making a choice of these constants are much the same as those considered by Guillemin (2).

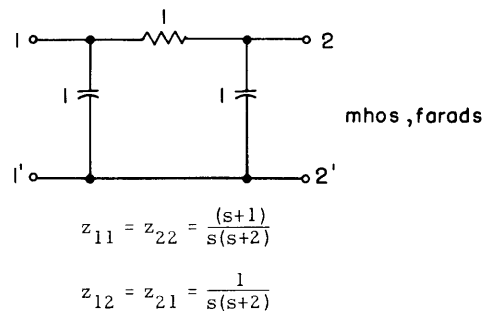
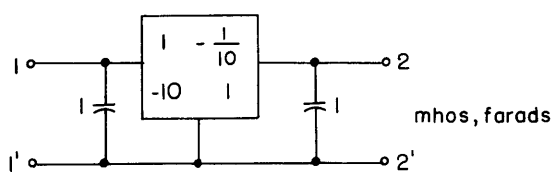

Fig. XIII-3. Original network of the first and second examples.

(XIII. NETWORK SYNTHESIS)



$$z_{11} = z_{22} = \frac{(s+1)}{s(s+2)}$$

$$z_{12} = \frac{1}{10s(s+2)} \quad z_{21} = \frac{10}{s(s+2)}$$

Fig. XIII-4. Final network of the first example.

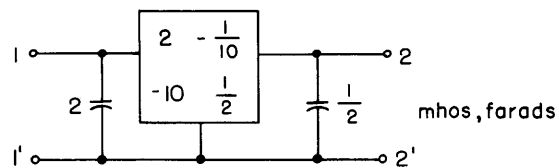

$$z_{11} = \frac{(s+1)}{2s(s+2)} \quad z_{22} = \frac{2(s+1)}{s(s+2)}$$

$$z_{12} = \frac{1}{10s(s+2)} \quad z_{21} = \frac{10}{s(s+1)}$$

Fig. XIII-5. Final network of the second example.

The methods of impedance leveling which he has discussed are actually special cases of the transformations of Eq. 3, the constraint being that $i = h^{-1}$ and $j = k^{-1}$, which leaves $P' = P$. If these constraints, which are required to conserve passivity, are removed, the process becomes that of simultaneous impedance leveling and power leveling. A few examples will be used to clarify the use of this idea.

EXAMPLE 1

Suppose that we want to hold the z_{11} and z_{22} of Fig. XIII-3 fixed but raise z_{21} by a factor of 10. The equilibrium equations are

$$E = [Z] I \text{ or } E = \begin{bmatrix} z_{11} & z_{12} \\ z_{21} & z_{22} \end{bmatrix} I \quad (13)$$

and we wish them to become

$$E' = \begin{bmatrix} z_{11} & cz_{12} \\ 10z_{12} & z_{22} \end{bmatrix} I' = [Z'] I' \quad (14)$$

Since

$$[Z'] = [A] [Z] [B]^{-1} = \begin{bmatrix} i^{-1}hz_{11} & j^{-1}hz_{12} \\ i^{-1}kz_{21} & j^{-1}kz_{22} \end{bmatrix} \quad (15)$$

we see that $i^{-1}h = 1$; $i^{-1}k = 10$; $j^{-1}k = 1$; $j^{-1}h = c$. From this it follows that $(i^{-1}h) \times (ik^{-1}) \times (j^{-1}k) = j^{-1}h = 1/10$, and thus we see that z_{12} must be lowered by a factor of $1/10$. Proceeding, we have

$$[G] = \begin{bmatrix} 1 & -1 \\ -1 & 1 \end{bmatrix} \quad (16)$$

and

$$[G'] = [B] [G] [A]^{-1} = \begin{bmatrix} 1 & -\frac{1}{10} \\ -10 & 1 \end{bmatrix} \quad (17)$$

The final network is shown in Fig. XIII-4. The capacitors have not been affected because the input and output impedances stay the same.

EXAMPLE 2

Starting with the same network as in Example 1, we wish to lower z_{11} by a factor of $1/2$, raise z_{22} by a factor of 2, and increase z_{21} by a factor of 10. Now we see that $i^{-1}h = 1/2$; $i^{-1}k = 10$; $j^{-1}k = 2$; $j^{-1}h = c$. Since $(i^{-1}h)(ik^{-1})(j^{-1}k) = j^{-1}h = 1/10$, it follows that $c = 1/10$, so that z_{12} is lowered by a factor of $1/10$. Proceeding, we have

$$[G] = \begin{bmatrix} 1 & -1 \\ -1 & 1 \end{bmatrix} \quad (18)$$

and

$$[G'] = \begin{bmatrix} 2 & -\frac{1}{10} \\ -10 & \frac{1}{2} \end{bmatrix} \quad (19)$$

The final network is shown in Fig. XIII-5. The capacitors have been changed in accordance with the impedance levels of their respective nodes.

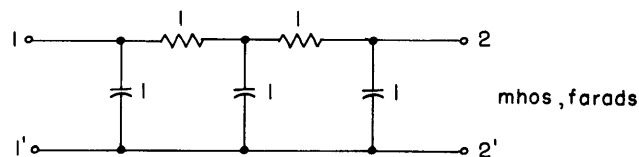

$$z_{11} = z_{22} = \frac{s^2 + 3s + 1}{s(s+1)(s+3)}$$

$$z_{12} = z_{21} = \frac{1}{s(s+1)(s+3)}$$

Fig. XIII-6. Original network of the third example.

EXAMPLE 3

We wish to increase z_{21} by a factor of 100 and to lower both z_{11} and z_{12} by a factor of $1/4$. (See Fig. XIII-6.) If we arbitrarily keep the impedance level at node b unchanged and share the transfer gain equally between the first coupling network and the second, we obtain for the network between a and b

(XIII. NETWORK SYNTHESIS)

$$\begin{bmatrix} \frac{1}{4} & c \\ 10 & 1 \end{bmatrix} = \begin{bmatrix} i^{-1}h & j^{-1}h \\ i^{-1}k & j^{-1}k \end{bmatrix} \quad (20)$$

with $i^{-1}h = 1/4$; $i^{-1}k = 10$; $j^{-1}k = 1$; and $c = j^{-1}h = 1/40$.

$$[G_{ab}] = \begin{bmatrix} 1 & -1 \\ -1 & 1 \end{bmatrix} \quad (21)$$

and thus

$$[G'_{ab}] = \begin{bmatrix} 4 & -\frac{1}{10} \\ -40 & 1 \end{bmatrix} \quad (22)$$

For the second coupling network,

$$\begin{bmatrix} 1 & d \\ 10 & \frac{1}{4} \end{bmatrix} = \begin{bmatrix} i^{-1}h & j^{-1}h \\ i^{-1}k & j^{-1}k \end{bmatrix} \quad (23)$$

with $i^{-1}h = 1$; $i^{-1}k = 10$; $j^{-1}k = 1/4$; and $d = j^{-1}h = 1/40$.

$$[G_{bc}] = \begin{bmatrix} 1 & -1 \\ -1 & 1 \end{bmatrix} \quad (24)$$

and it becomes

$$[G'_{bc}] = \begin{bmatrix} 1 & -\frac{1}{10} \\ -40 & 4 \end{bmatrix} \quad (25)$$

The final network is shown in Fig. XIII-7.

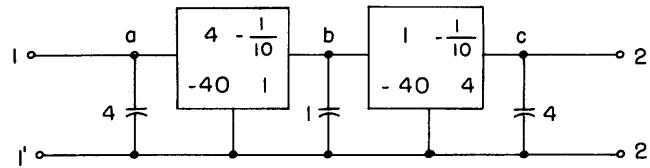

$$z_{11} = z_{22} = \frac{(s^2 + 3s + 1)}{s(s+1)(s+3)}$$

$$z_{21} = \frac{100}{s(s+1)(s+3)} \quad z_{12} = \frac{1}{1600s(s+1)(s+3)}$$

Fig. XIII-7. Final network of the third example.

Again, the capacitors have been changed in accordance with the impedance levels of their respective nodes.

We want to point out that the active boxes used here to denote the transformed $[G']$ matrices cannot be realized as easily as might be imagined. In all of these examples the $[G']$ matrices are singular. It is difficult, or perhaps impossible, to find a single transistor or single vacuum-tube circuit characterized by a singular parameter matrix. However, the usefulness of these techniques is not marred by this drawback. First, if the resistors do not appear singly, as they did in the examples, but in pairs as an "ell" or "gamma" (a situation that can often be induced), the same techniques can be used to produce a nonsingular $[G']$ matrix that can be realized by a single vacuum tube or transistor. At present, no procedures have been worked out for accomplishing this, but some preliminary investigations have revealed that a procedure can be found. Second, these techniques are of academic value because they point out in a clear manner how gain and nonbilaterality are inserted into a network by means of an active device. Third, transformation techniques can be used backwards in an analysis problem. Here, again, we are given an advantage in that we can see those factors that contribute to gain as opposed to those that contribute to nonbilaterality and to other characteristics as the active network is reduced step by step to a simple passive network.

T. G. Stockham, Jr.

References

1. E. A. Guillemin, Synthesis of Passive Networks (John Wiley and Sons, Inc., New York, 1957).
2. Ibid., Chapter V.