

## XXI. SHOP NOTES

### A. SHORT SPIRAL BAFFLES

#### 1. Applications

Short spiral baffles of a type described below were used successfully in the Molecular Beams Laboratory (RLE) with oil and mercury diffusion pumps and as liquid-nitrogen-cooled radiation shields for liquid-helium traps. This type of baffle can also be used to stop stray ions from entering ionization gauge tubes by placing it in the gauge tubulation, as shown in Fig. XXI-1. It also acts as a waveguide beyond cutoff for preventing stray rf fields from entering the vacuum system.

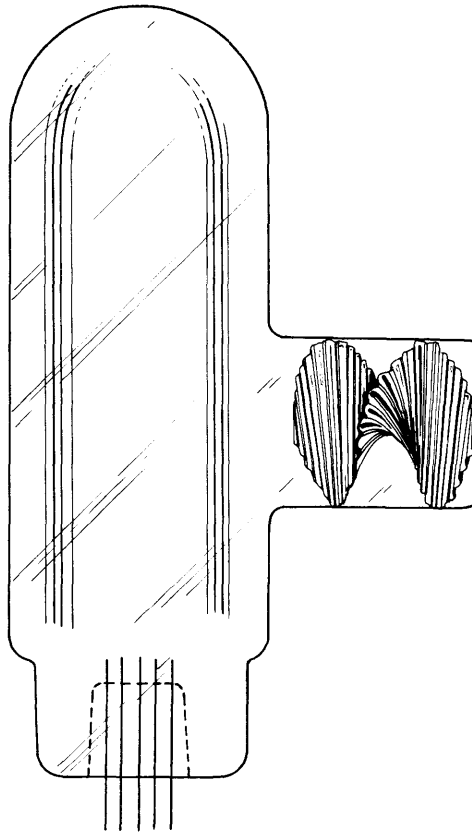

Fig. XXI-1.

With these corrugated baffles many turns can be made easily and quickly within a short length, whereas flat metal spirals cannot be formed closely without difficult and lengthy machining.

Another advantage is that, for a given thickness of material, more cooling area is

(XXI. SHOP NOTES)

exposed, and better cooling is effected by having a greater cross-sectional area of metal in contact with the cooling source than can be achieved with flat spirals. Also, gas molecules have to collide with the walls a greater number of times to pass through this baffle than in other designs of equivalent length and pumping speed.

A convenient method for making efficient short baffles for vacuum systems without reducing the pumping speed excessively can be described as follows.

An annealed thin copper sheet of dimensions that can be determined from Eq. 1 is passed through a gear roller (Fig. XXI-2) that is built of standard pinion stock. Rollers are so selected that the working depth of the teeth agree, or agree as nearly as possible, with the  $d$  of Eq. 1. The thin metal sheet comes out of the rollers in a corrugated form and, after being annealed again, can easily be shaped by hand around a cold trap (Fig. XXI-3) by compressing one side of the corrugations and stretching the other. The spiral is held in place by tacking the beginning and the end with solder. Then the soldering is completed.

A variation of the corrugated baffle that is water cooled and allows twice the

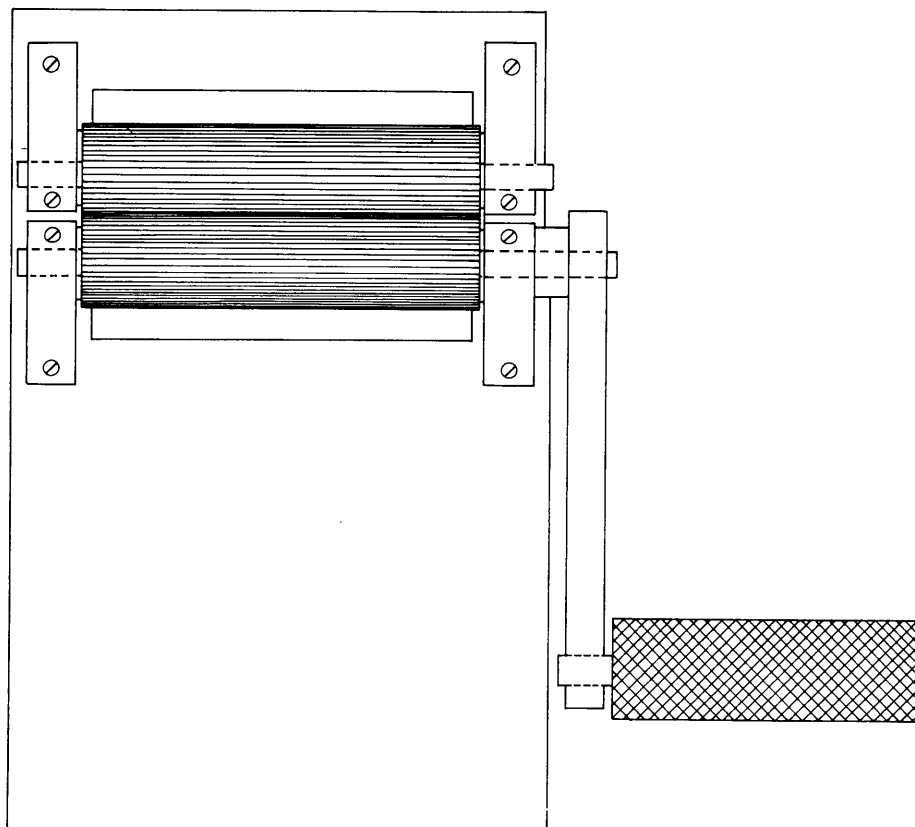

Fig. XXI-2.

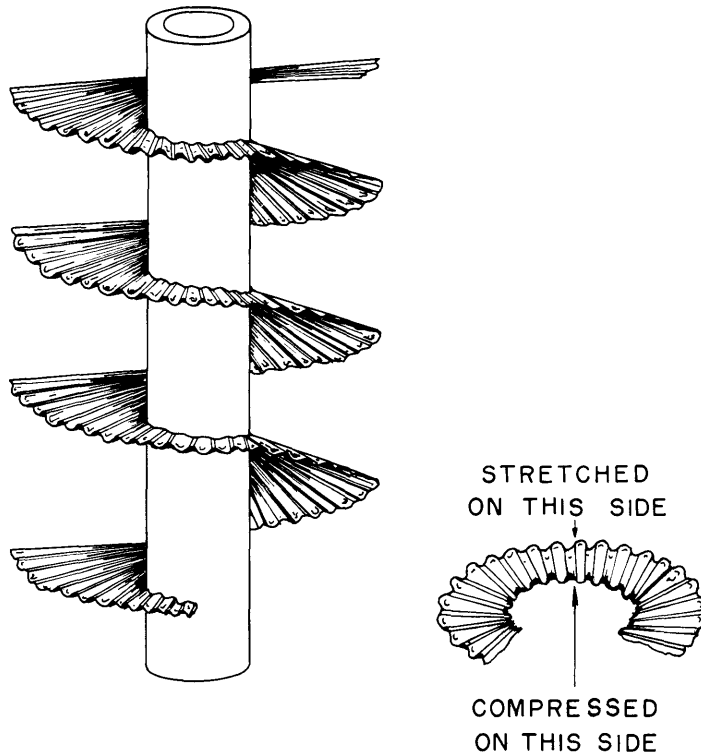

Fig. XXI-3.

pumping speed is shown in Fig. XXI-4. This baffle can be cooled with liquid nitrogen by the method shown in Fig. XXI-5. In this design the corrugations are compressed in the center and stretched at the ends, and simultaneously twisted so that a double-spiral stairway effect is formed.

## 2. Internal Spiral Pipe Baffles

The width of metal equals the diameter of baffle.

The length,  $L$ , is given by

$$L = \frac{2r\omega}{d} \quad (1)$$

where  $L$  is the length of the baffle for 1 revolution,  $r$  is the radius of the baffle,  $d$  is the working depth of the pinion tooth, and  $\omega$  is the compressed thickness per corrugation. (See Fig. XXI-4.) Theoretically,  $\omega$  is twice the thickness of the metal. In practice it is between 0.031 inch and 0.041 inch when 4-8 mil metal is used.

The working depth of tooth is twice the addendum.

The length of material before corrugating,  $l$ , is given by

$$l = 2\pi r \text{ per revolution} \quad (2)$$

(XXI. SHOP NOTES)

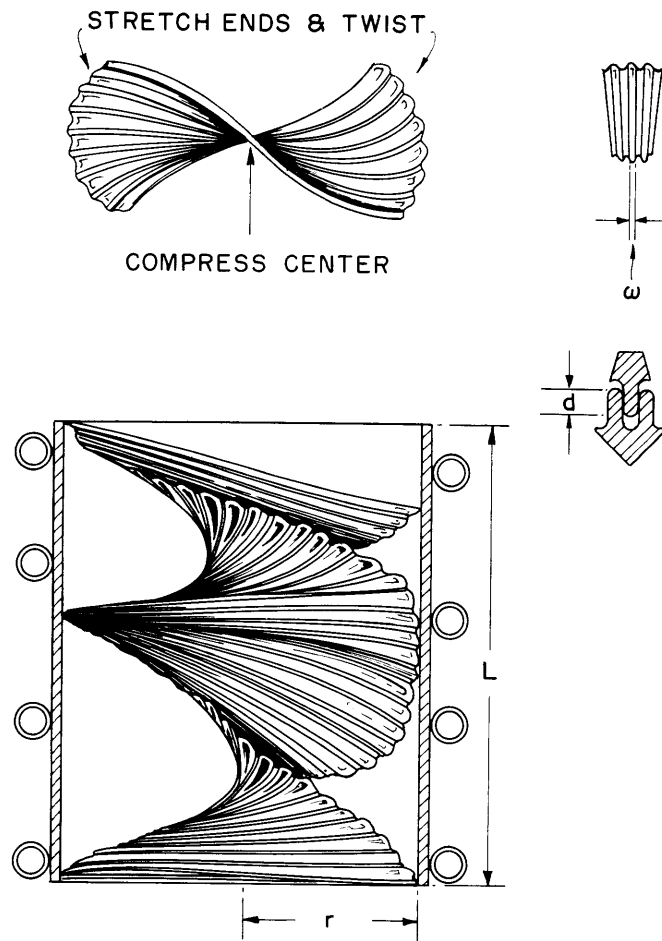

Fig. XXI-4.

3. External Spiral Pipe Baffle

The width of the corrugated sheet is

$$W = \frac{D - d}{2} \tag{3}$$

where  $D$  is the diameter of the baffle, and  $d$  is the diameter of the pipe.

The length of the uncorrugated metal is  $\ell = \pi D$  per revolution. Metal of 4-8 mils is used. The spacing between the revolutions in this case can be as close as desired.

Pinion stock of from 24 to 32 pitch has been used extensively with excellent results for baffles from 0.5 inch to 6 inches in diameter.

4. Comments

Baffles can be conveniently soft-soldered or hard-soldered with a hand torch, or they can be soldered in a furnace with silver-copper eutectic.

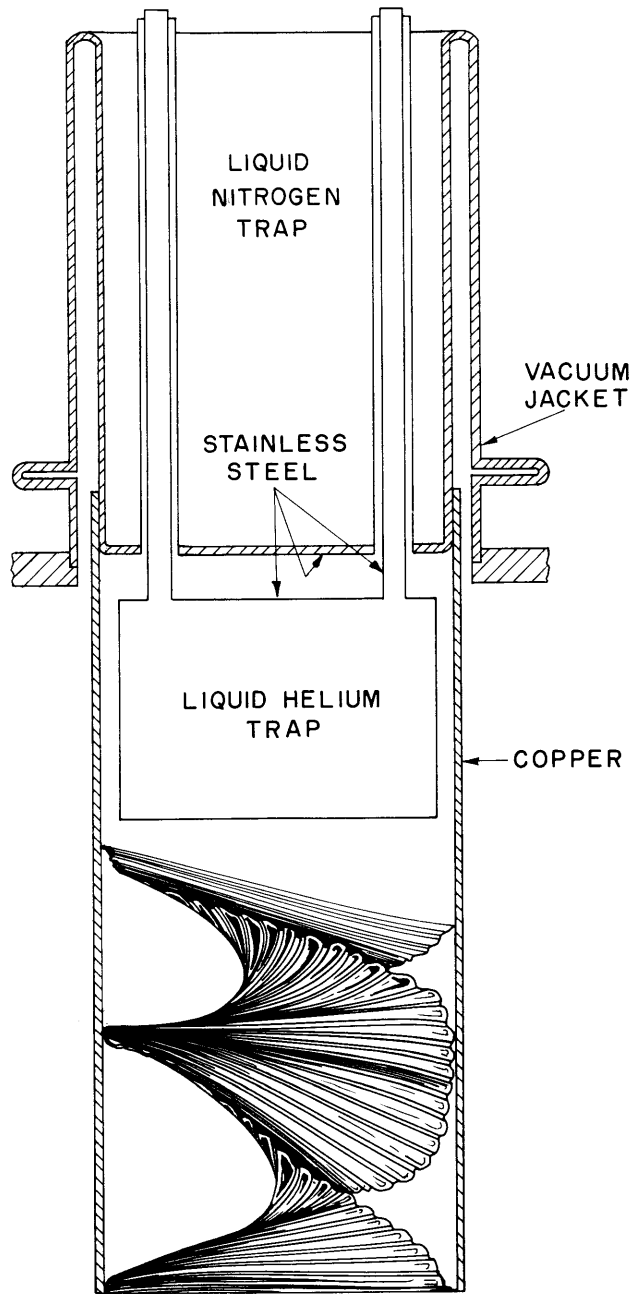

Fig. XXI-5.

(XXI. SHOP NOTES)

Baffles of more than 6 inches in diameter were very difficult to form because, with the available standard pinion stock, the stretch of corrugations is not great enough to allow the required perimeter length.

Copper and nickel were used, in thicknesses ranging from 0.0035 to 0.010 inch.

Several annealings with a hand torch may be necessary when using the thicker material.

Usually  $1 \frac{1}{4}$  to  $1 \frac{1}{2}$  revolutions are sufficient for the purposes described in this report.

F. J. O'Brien